



Otter Pro X-Over Lodge Installation and Set-Up Instructions

Otter Pro X-Over Lodge Fits Magnum Otter II & Pro Sled Only Parts Identification and Check List

MODEL NUMBERS:

Complete Pkg Pro X-Over Lodge 201152

PARTS LIST

Item #	Qty	Part #	Description
1	1	201067	Sled - Dark Gray
2	1	201140	Tent - Pro X-Over Lodge
3	1	201232	Frame Bracket "A"
4	1	201233	Frame Bracket "B"
5	1	201207	Back Adjustable Pole
6	1	200493	Top Back Support Pole
7	1	201408	Top Front Support Pole - Adjustable
8	1	200362	Front Adjustable Support Pole
9	2	201215	Left Side Back and Center Elbow and Extension
10	2	201216	Right Side Back and Center Elbow and Extension
11	1	201217	Left Side Front Elbow and Extension
12	1	201218	Right Side Front Elbow and Extension
13	1	201406	Left Side Bottom Elbow and Extension
14	1	201407	Right Side Bottom Elbow and Extension
15	3	201221	Middle Main Frame
15a	1	201379	Middle Main Frame with Pivot
16	2	201154	Seat
17	2	200369	Seat Bracket
18	2	200806	Seat Base
19	1	200379	Seat Rail - 67"
20	2	200196	Seat Rail Cap
21	2	200376	Seat Rail Bracket
22	4	400641	#8 x 3/4" Self Tapping Screw
23	6	200195	Black End Cap
24	8	200615	5/16 Washer
25	4	401017	1/4 x 3/4 Hex Bolt
26	14	400648	1/4 Nylon Hex Lock Nut
27	2	400367	5/16 x 2 Hex Bolt
28	2	200787	5/16 Nylon Hex Lock Nut
29	30	200942	7/16" Self Tapping Screw
30	1	201159	Plastic Trim Lock Kit
31	1	201370	Quick Switch Bracket Kit - Pro

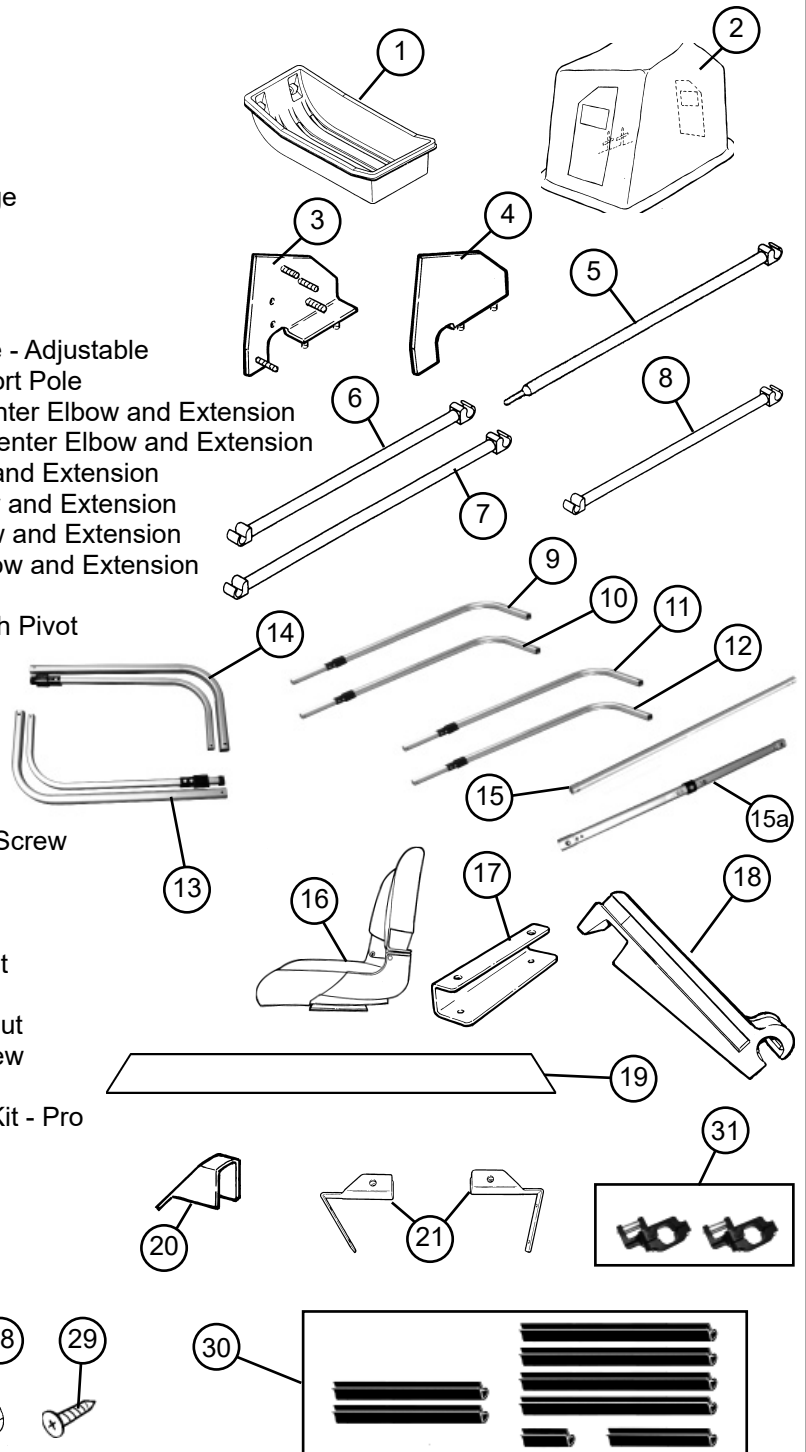

Tools Required:

Ratchet & 7/16" socket

7/16" Wrench

Short Extension for Ratchet or 7/16" deep socket

Drill/Driver

Phillips Bit

Phillips Screwdriver

1/2" Wrench

1/2" Socket

5/16" Drill Bit

7/16" Drill Bit

NOTE: Installing the seating system before assembling the frame and canvas will make installation easier.

**** Seat slide brackets are preassembled to the swivel.**

1. Install the seat slide brackets onto the seat swivel using the flathead machine screws and nylock nuts and washers. Leave the bolts loose enough to allow them to be adjusted. The factory instructions are shown if adjustments or disassembly are required.

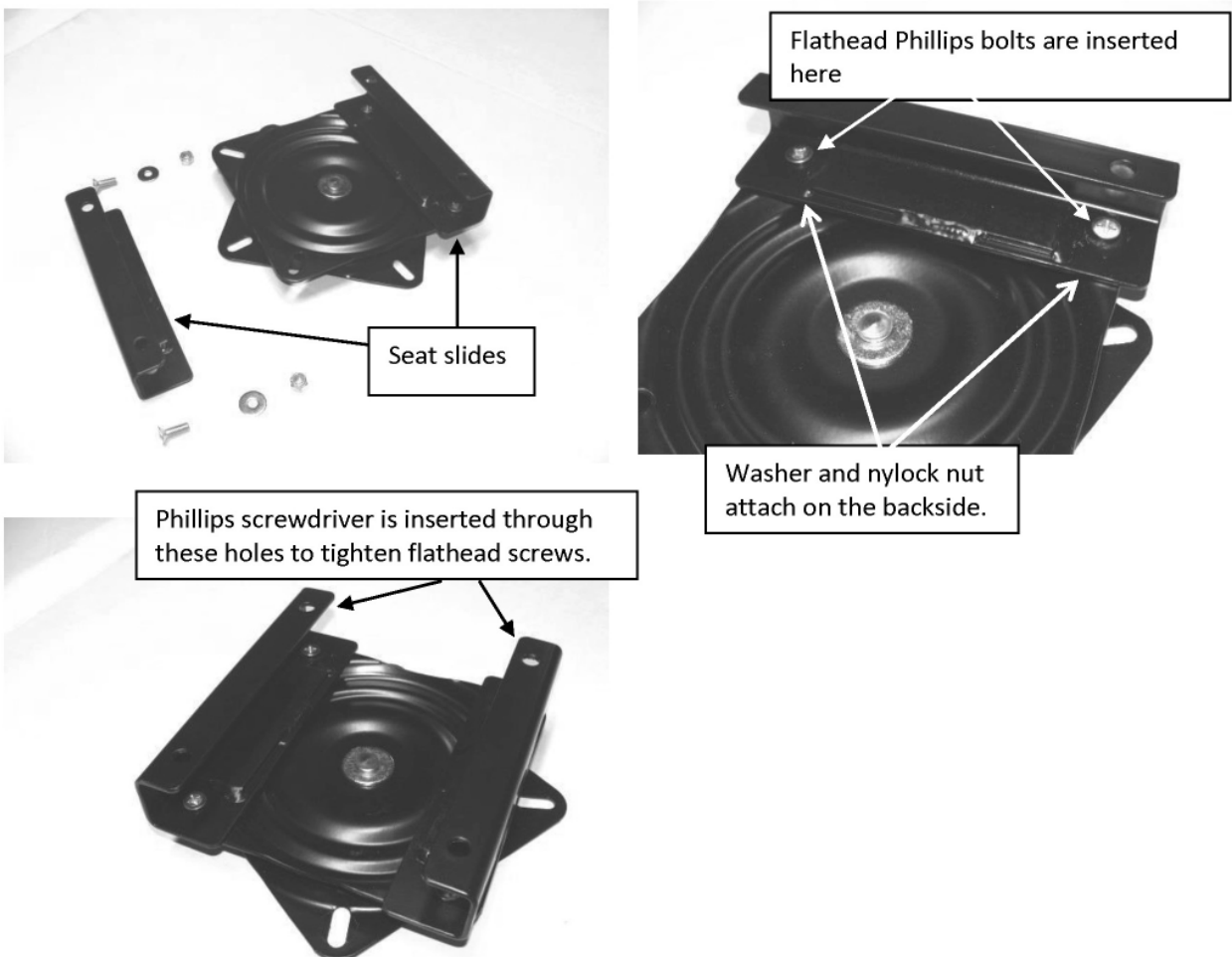

2. Slide brackets and swivel part way onto the plastic base. Adjust the fit to be snug by pressing in on the brackets. However the brackets still need to be able to slide smoothly back and forth on the plastic base. Tighten the bolts securely once the fit is correct.

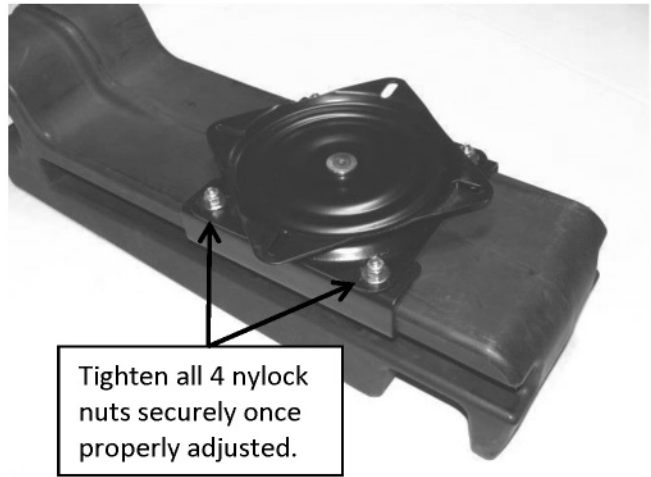
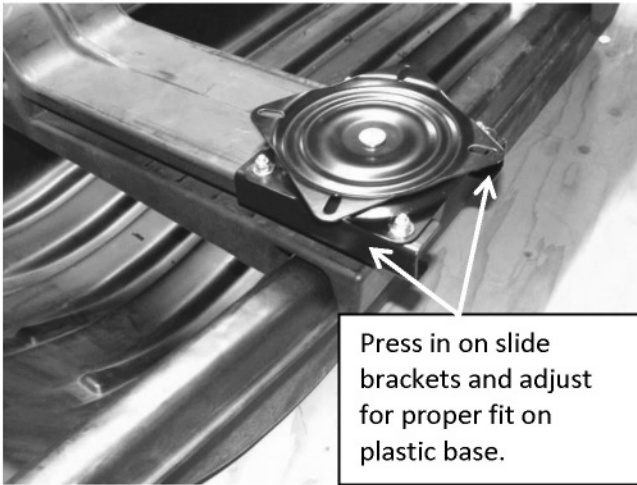

3. Line up the swivel with the inserts in the bottom of the seat. Loosely install the 1/4" x 3/4" phillips head bolt with washers (included in the seat box) into the inserts in the bottom of the seat. Tighten all 4 bolts securely once the swivel is properly positioned.

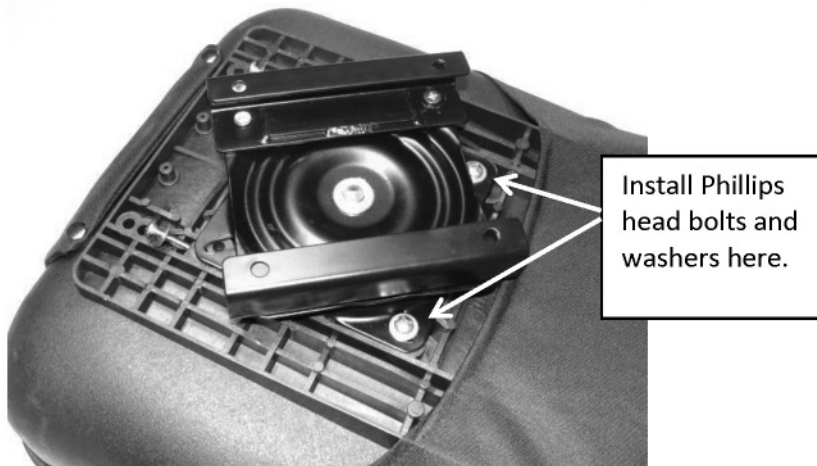

4. Drill out the four pre-marked holes for the seat rail brackets as shown using a 5/16" drill bit. The sled may be tipped upside down to make drilling the holes easier.

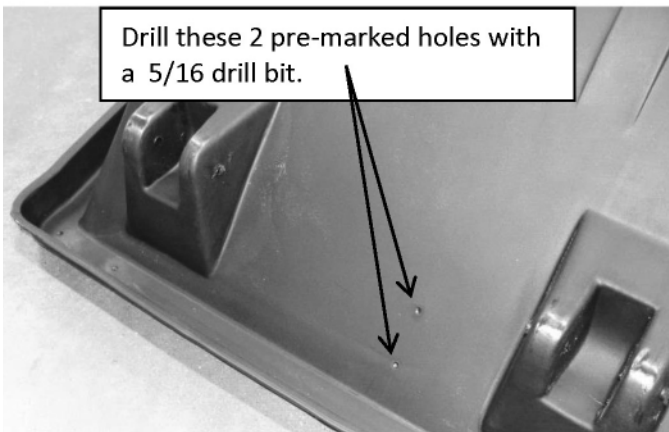
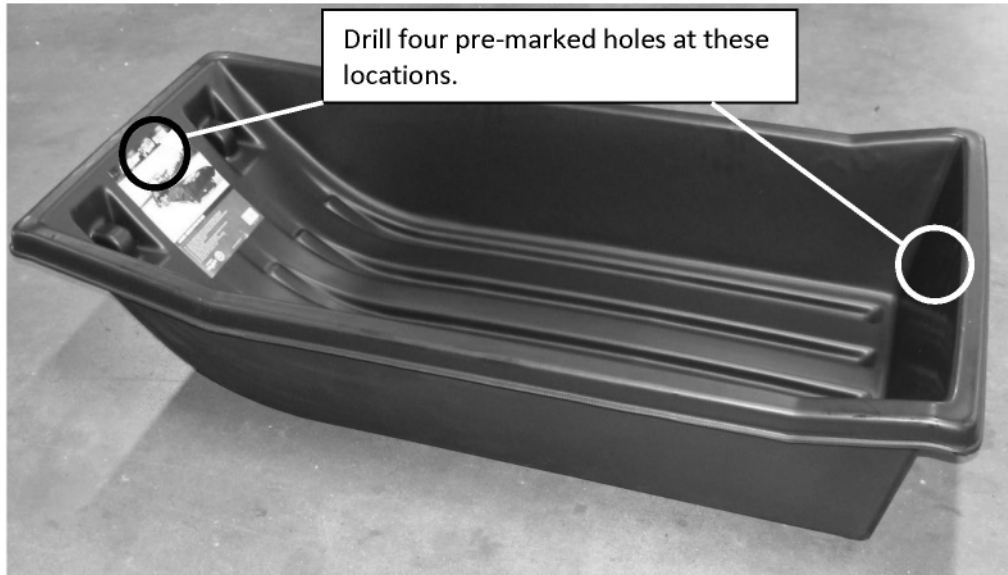

5. Attach the metal brackets to the seat rail using the 5/16" bolts and nuts. The bracket with the greater angle goes toward the front of the sled. Attach plastic end caps onto the seat rail using the self tapping screws. A small pilot hole may be drilled to ease installation.

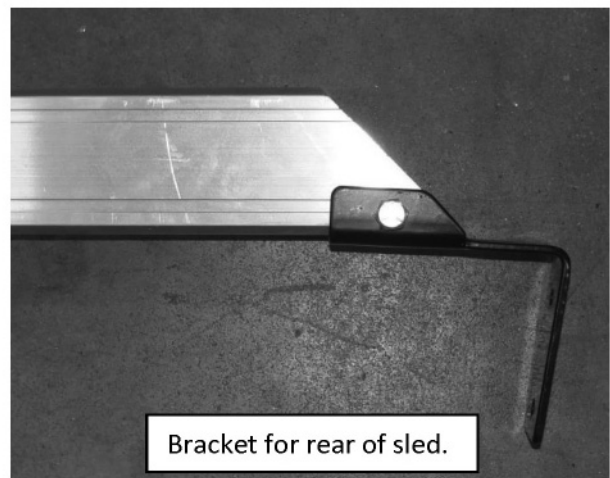

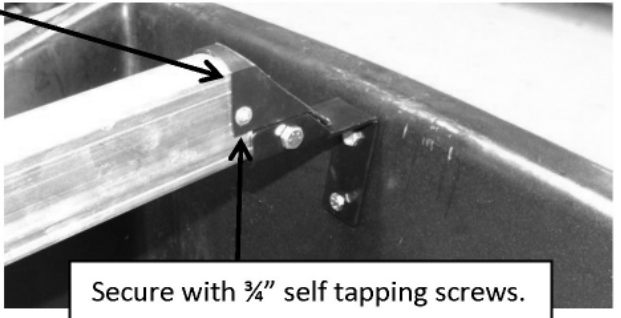
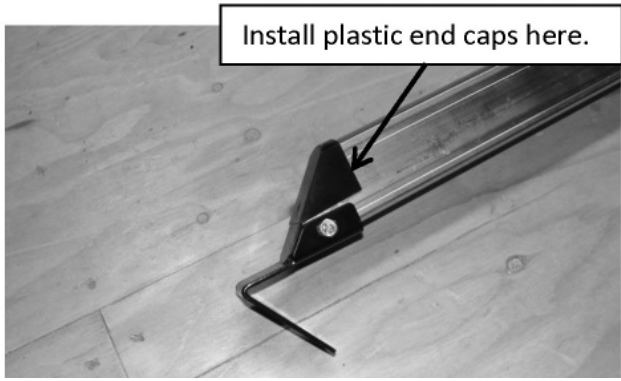

6. After the brackets and end caps are installed, the seat rail may be bolted into place with the 1/4" bolts, washers and nylock nuts using the previously drilled holes. Install plastic base and seat onto the rail. Use WD-40 or silicone to lubricate plastic seat base opening so it will go onto the aluminum rail easier.

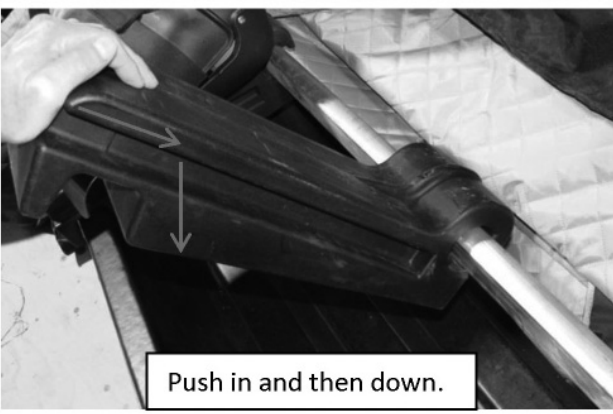
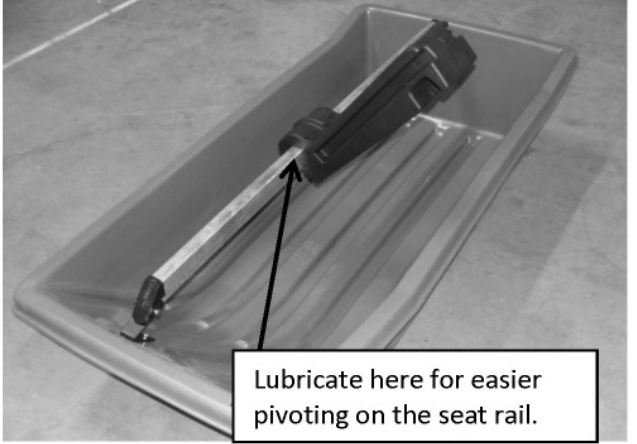
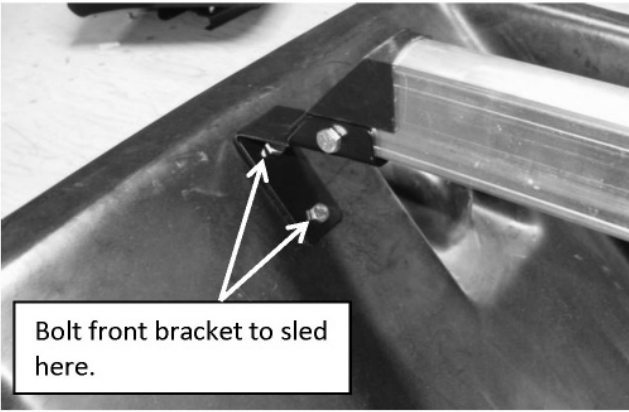
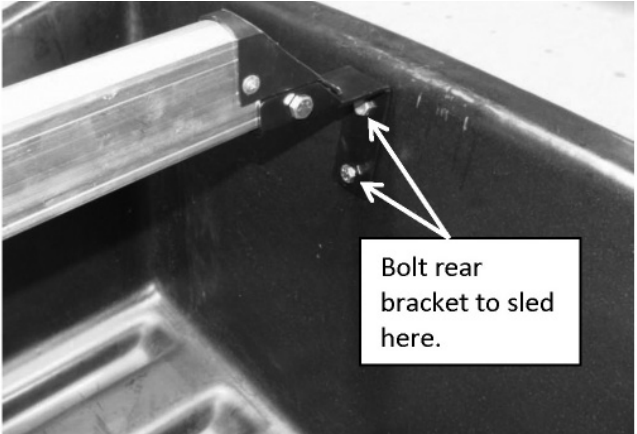

Note: Seat assembly not shown for clarity.

7. Position sled (Item 1) as shown with curved front to your left.
8. Drill the 4 marked holes using a 5/16" bit.
9. Drill the 7/16" hole in center of lip approximately 16" from bend in sled. The back adjustable pole (Item 5) not shown) is to be propped here.

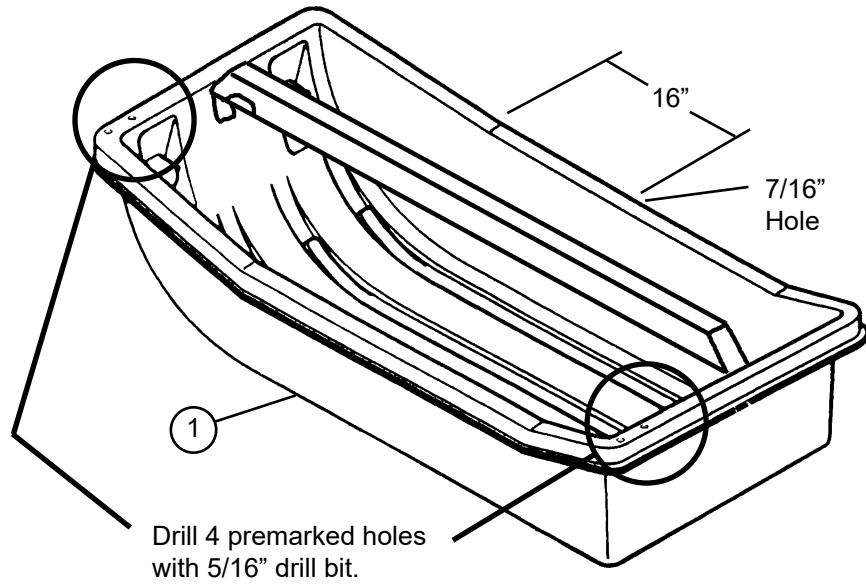

10. Bolt frame brackets (Item 3 and Item 4) to sled using holes predrilled in Step 8. Use appropriate fasteners as shown.

Diagram 8

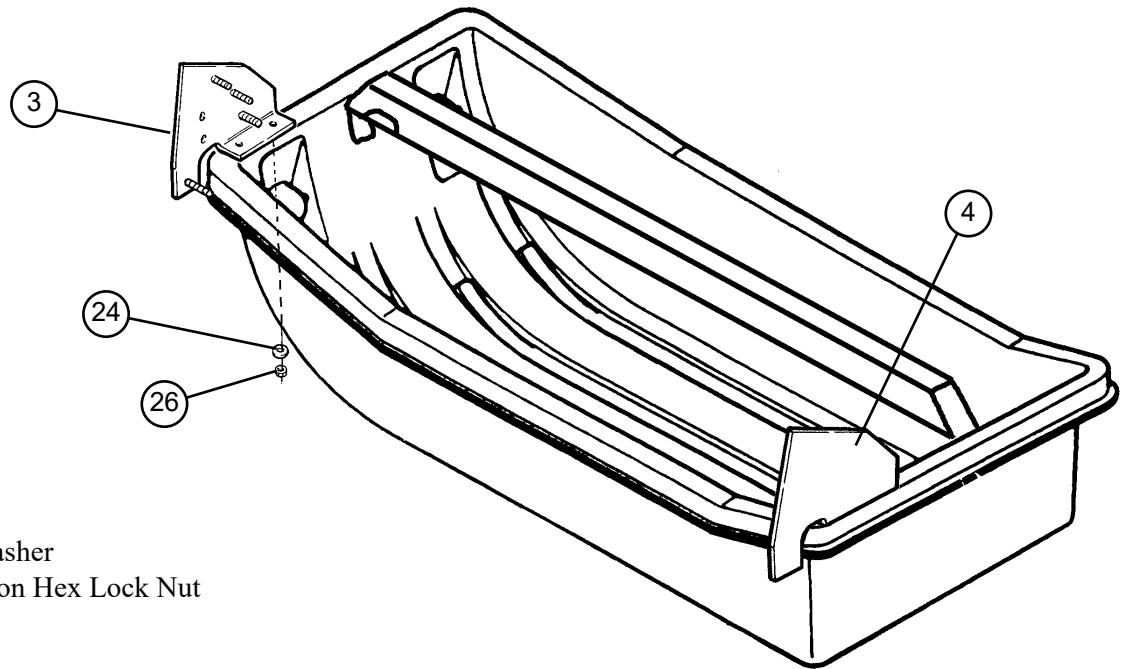

Item 24 - 5/16 Washer

Item 26 - 1/4 Nylon Hex Lock Nut

11. Position middle main frame (Item 15), left side back and center elbow and extension (Item 9), and right side back and center elbow and extension (Item 10) as shown. Align locking mechanism in item 15 with square cutout in items 9 and 10 and slide together until they lock. Repeat this procedure to create another main frame bar.

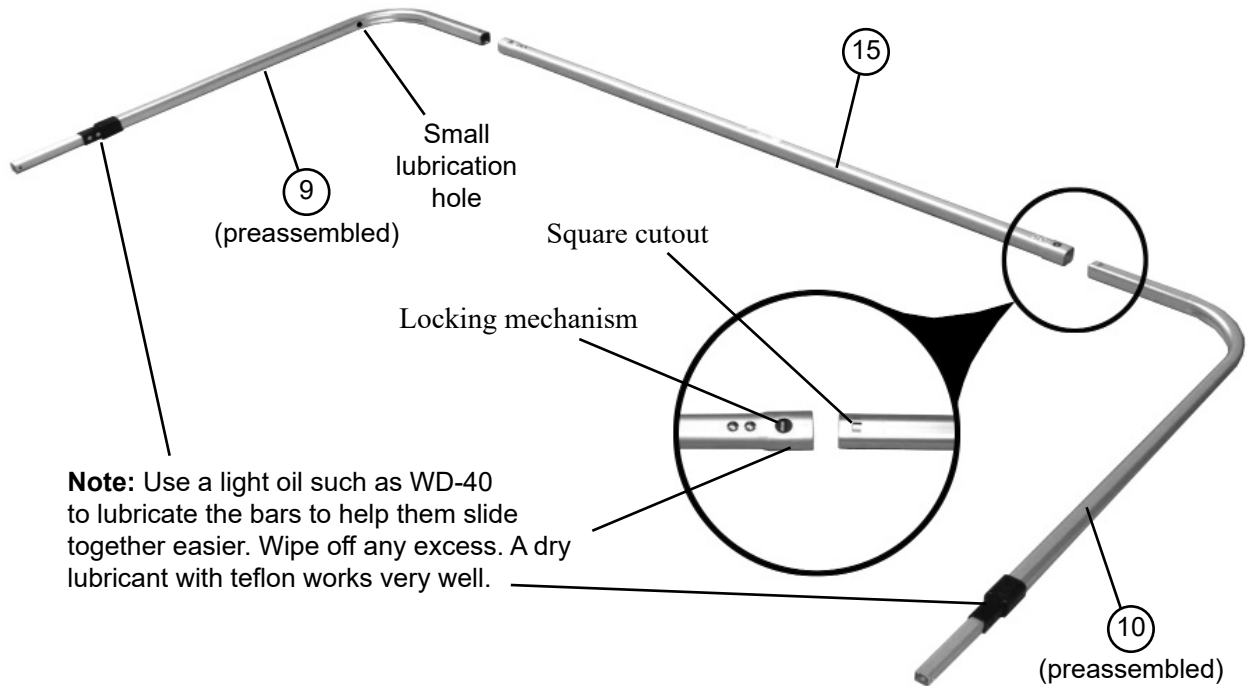

Note: These two assemblies are for the Back and Center Main Frame Bars.

12. Position middle main frame with pivot (Item 15a), left side front elbow and extension (Item 11), and right side front elbow and extension (Item 12) as shown. Align locking mechanism in item 15a with square cutout in items 11 and 12 and slide together until they lock. Lubricate frame bars for best operation as shown in step 11.

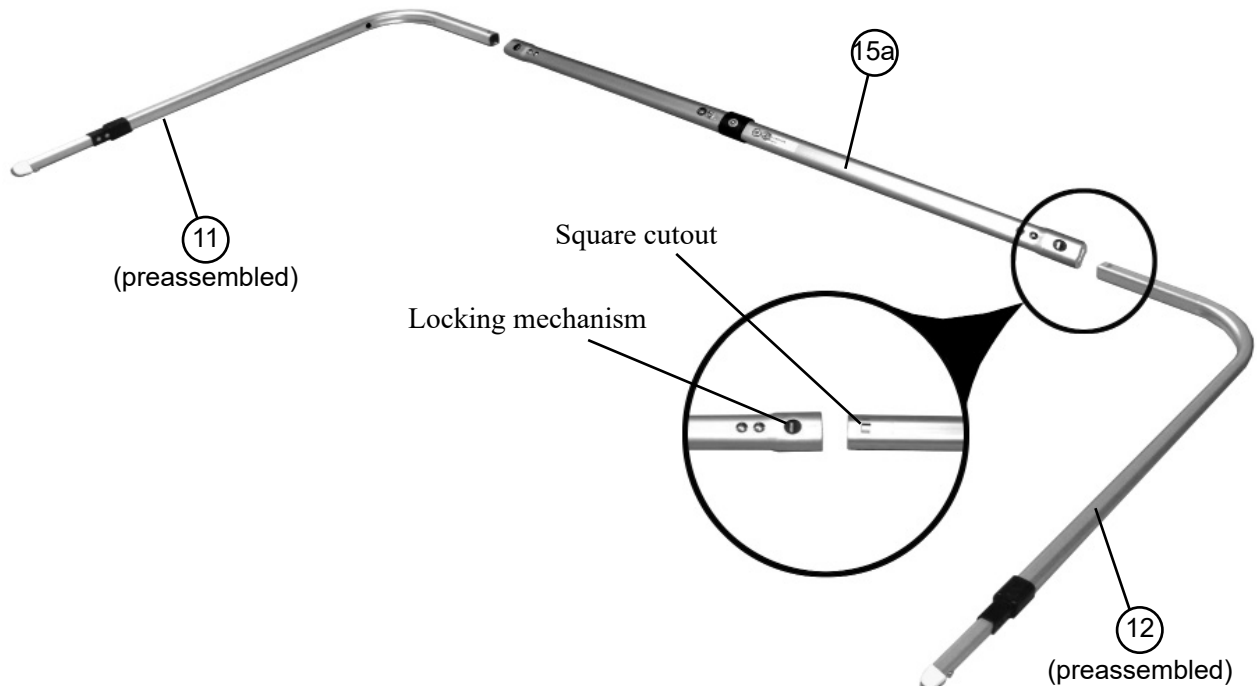

Note: This assembly is for the Front Main Frame Bar.

13. Slide one tube inside the other as shown for the left side bottom elbow and extension (Item 13) and the right side bottom elbow and extension (Item 14).

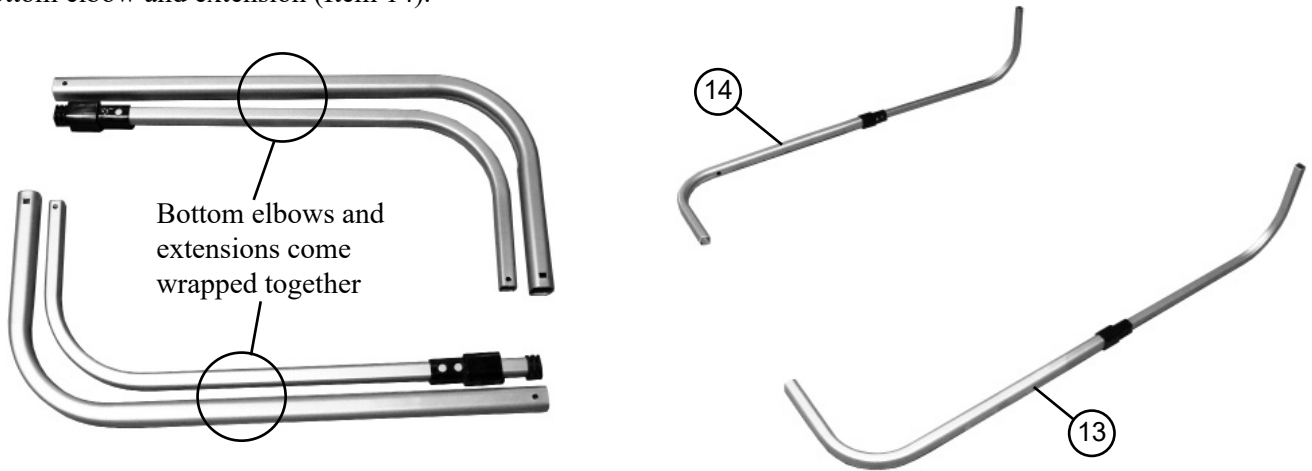

14. Attach quick switch brackets (Item 31) onto items 14 and 13.

Note: Offset goes to the inside of the shelter.

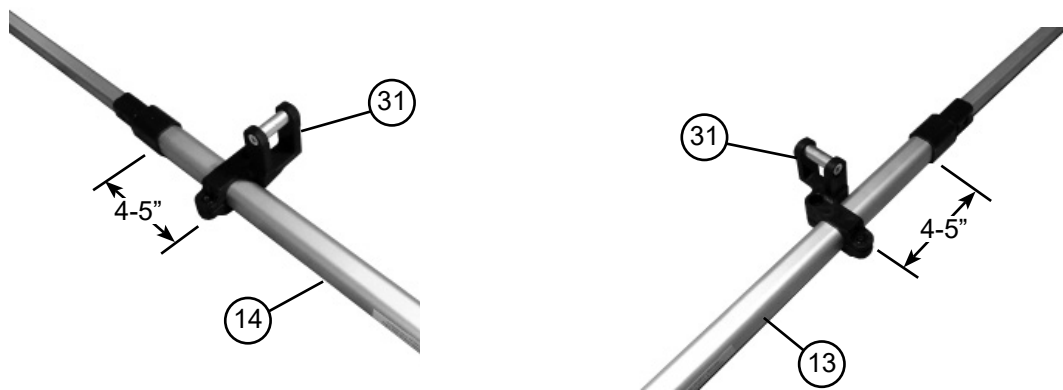

15. Slide middle main frame (Item 15) onto items 13 and 14 assembled in step 13 and lock together. Lubricate frame bars for best operation as shown in step 11.

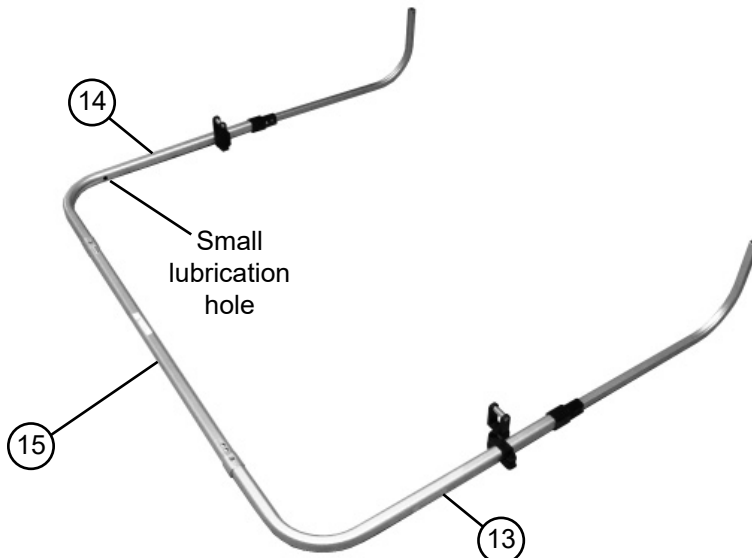

Note: This assembly is for the Bottom Main Frame Bar.

16. Insert a black end cap (Item 23) onto each end of the back main frame bar and attach the back main frame bar to the frame brackets (Item 3 and 4) in location shown and secure with 1/4" nylon hex lock nuts (Item 26)

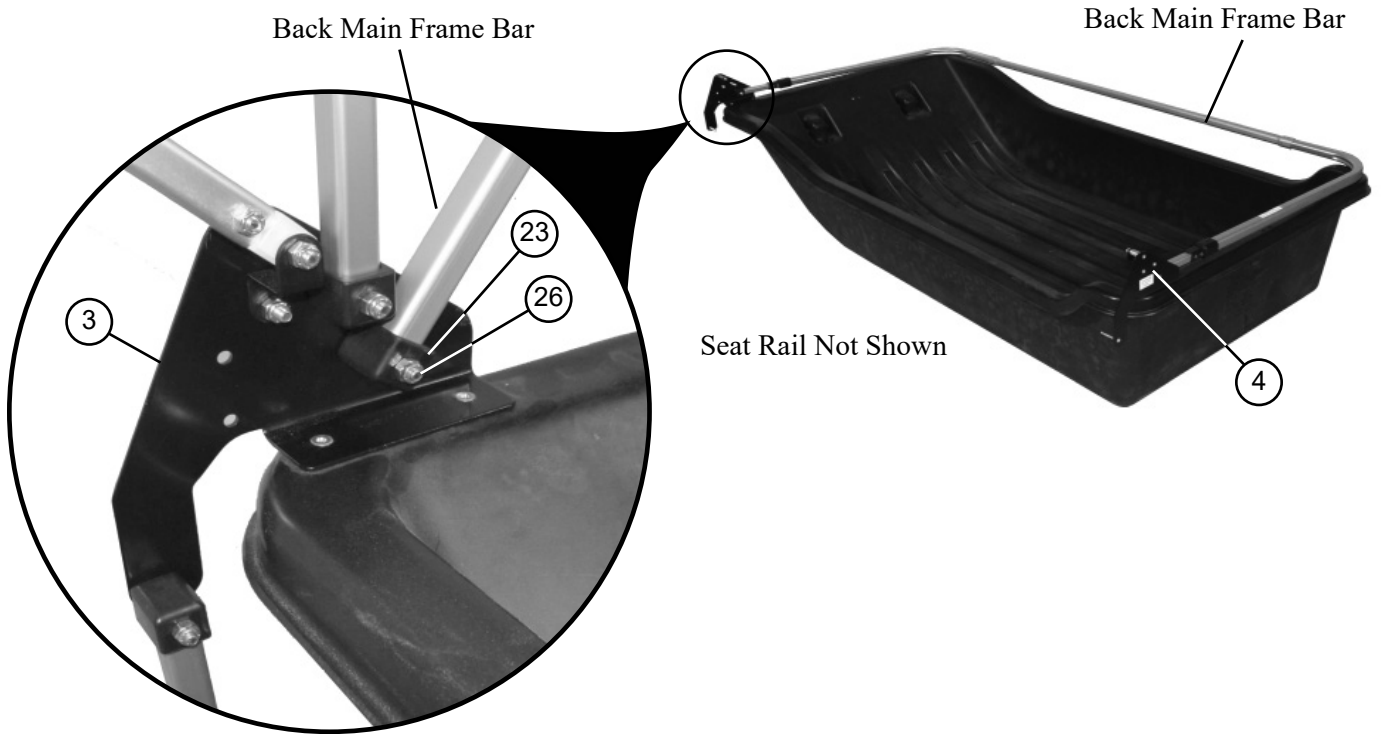

17. Insert a black end cap (Item 23) onto each end of the center main frame bar and attach the center main frame bar to the frame brackets (Items 3 and 4) in location shown and secure with 1/4" nylon hex lock nuts (Item 26)

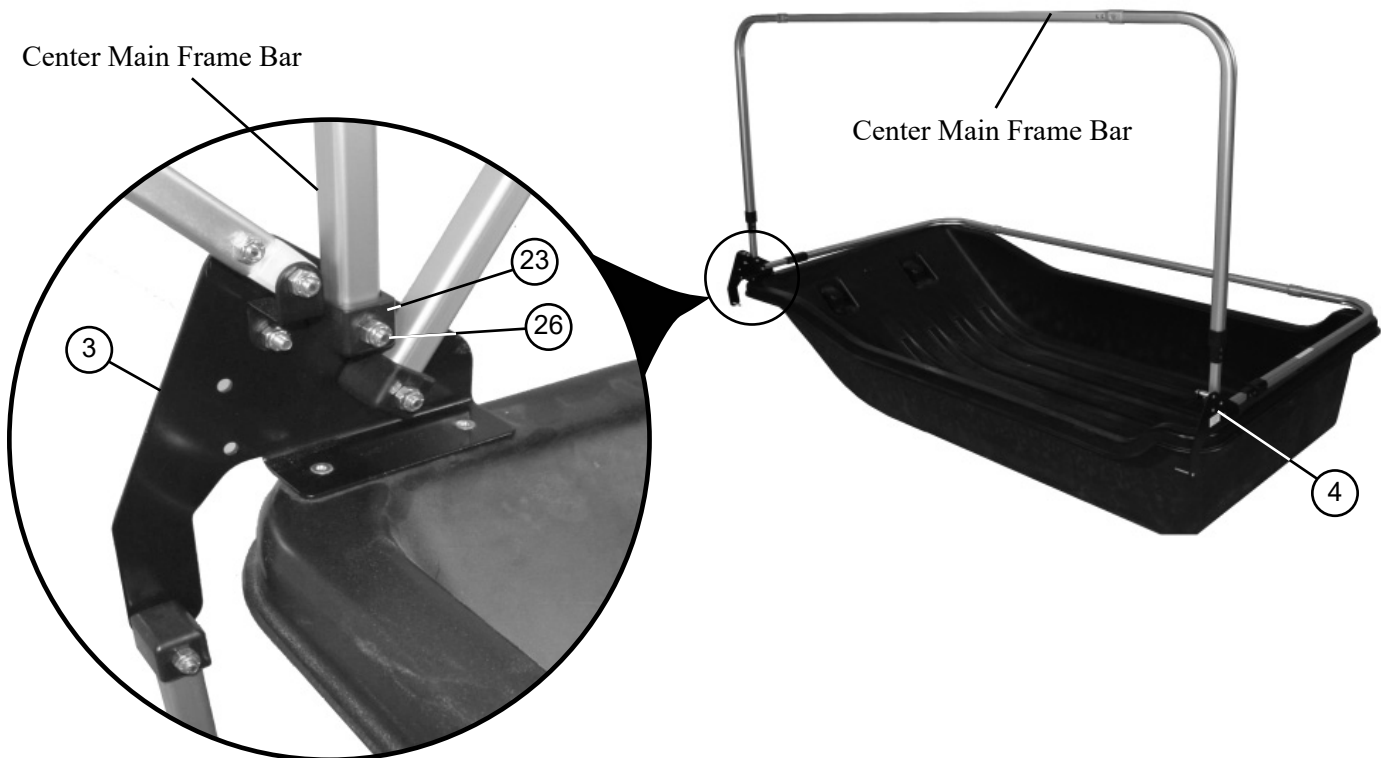

18. Attach the front main frame bar to the frame brackets (Items 3 and 4) in location shown by pushing the white conversion clips onto the aluminum bushings on the brackets.

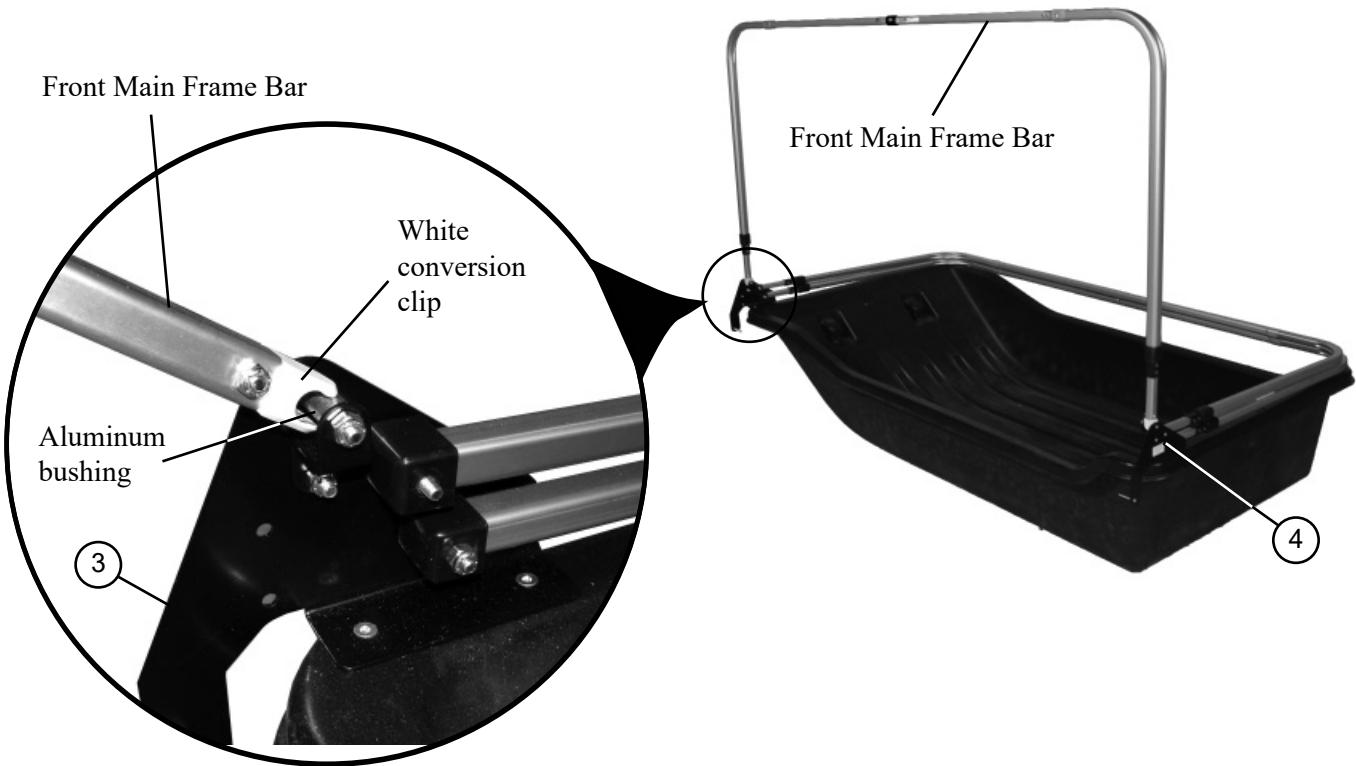

19. Insert a black end cap (Item 23) onto each end of the bottom main frame bar and attach the bottom main frame bar to the frame brackets (Items 3 and 4) in location shown and secure with 1/4" nylon hex lock nuts (Item 26)

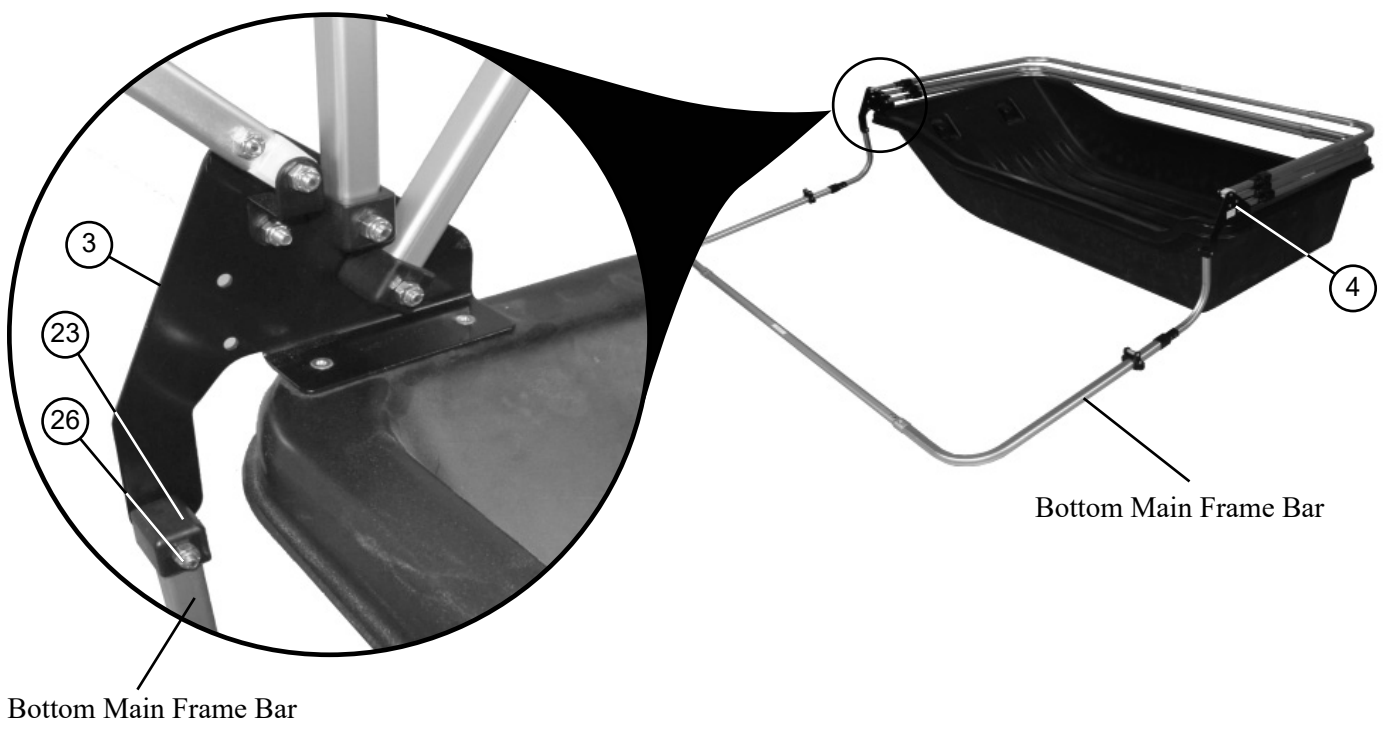

20. Set up main frame bars by grasping with both hands and pushing upward until button clicks into place. Start with bottom main frame bar and continue to the back main frame bar pushing lengthened bars into appropriate position.

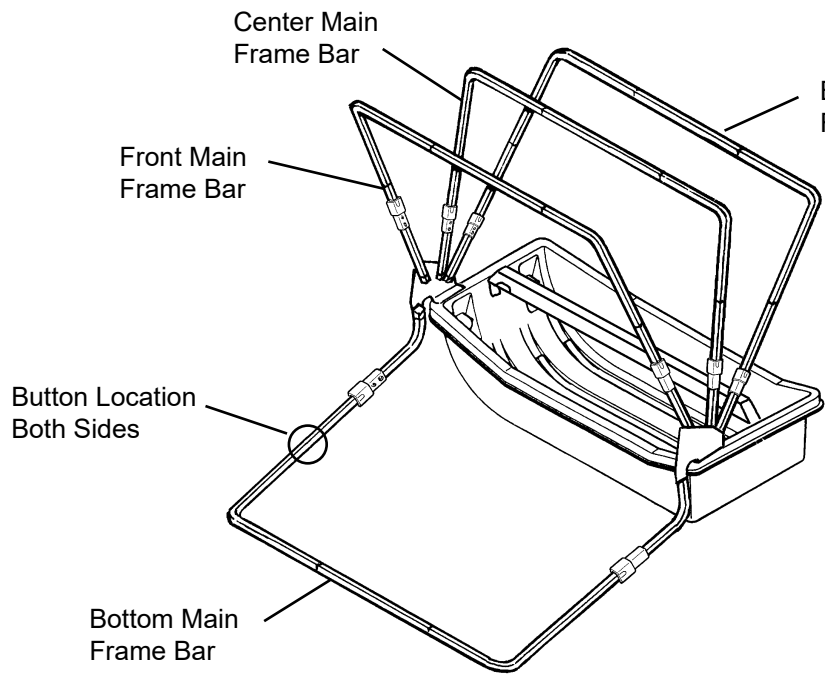

Note: Seat assembly not shown for clarity

Note: There are two holes that the buttons can click into to optimize the fit of the canvas.

21. Install back adjustable pole (Item 5) as shown first. Install top back support pole (Item 6) as shown next. Install top front support pole (Item 7) as shown next. Install front adjustable support pole (Item 8).

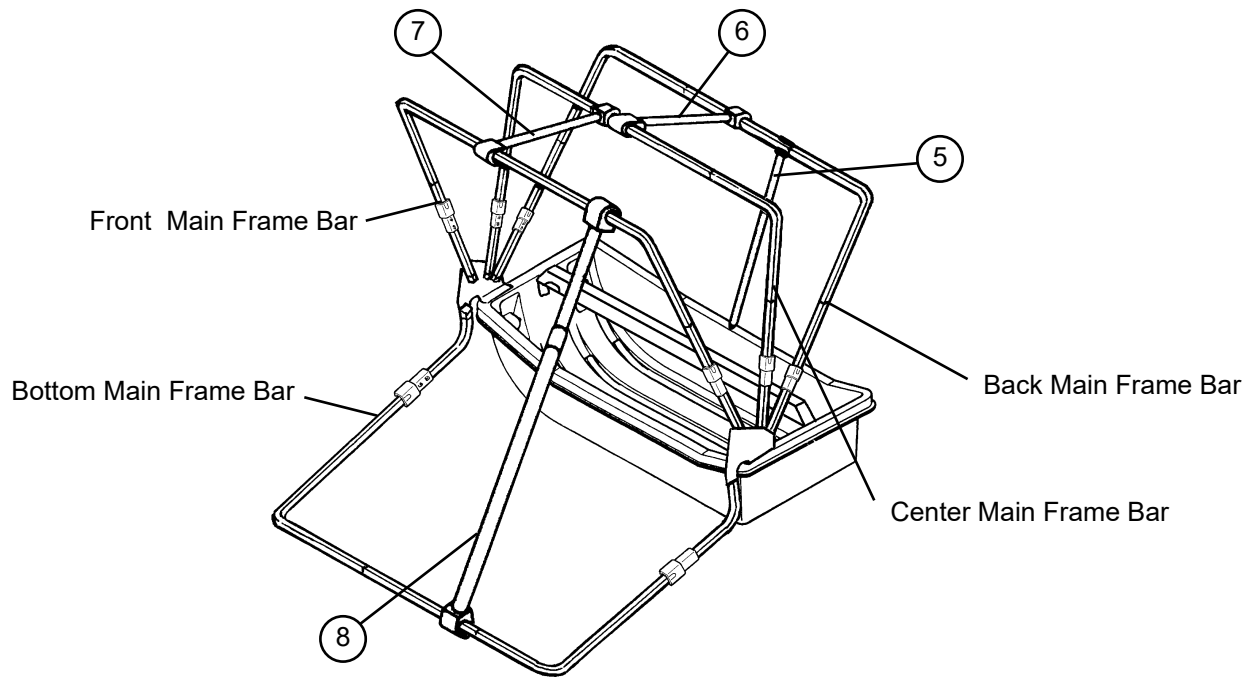

Converting front main frame bar from normal position to side door position.

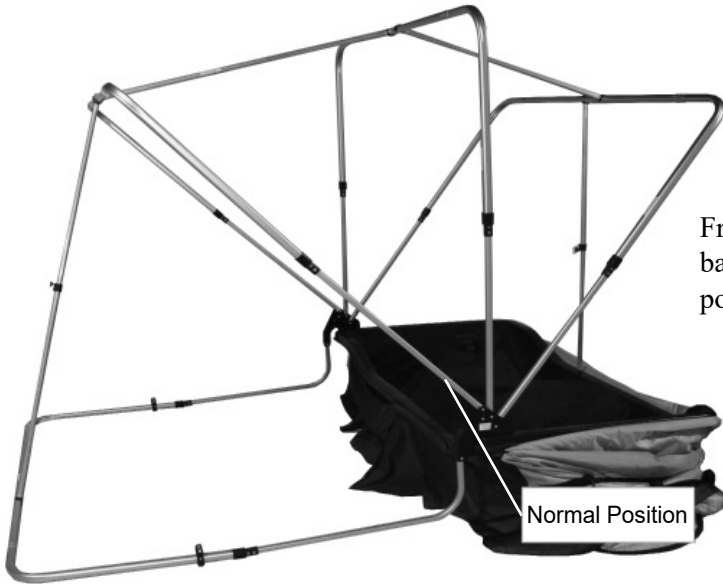

Front main frame bar shown in normal position.



- A. All support poles should be installed.
- B. Unclip the front main frame bar from the frame brackets (Items 3 and 4), move it forward and clip it onto the side door brackets.
- C. Adjust support poles and frame bars as necessary to achieve the best fit.

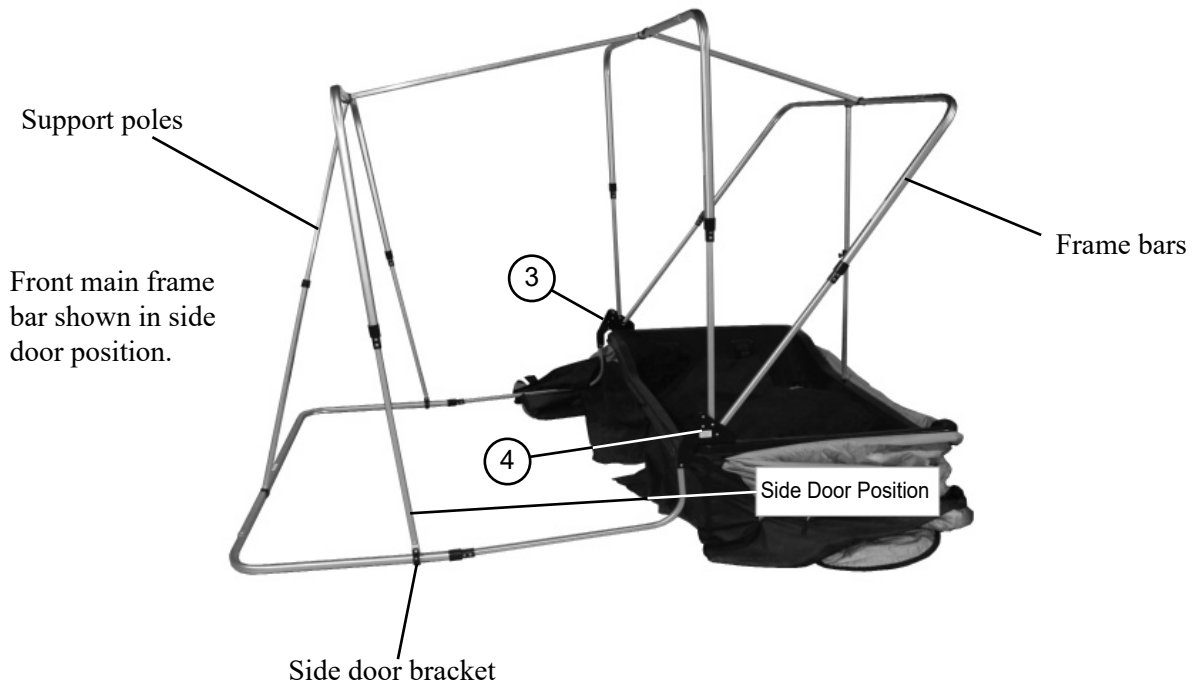

22. Slide the tent over the main frame bar assembly, then fasten the velcro straps on the inside of the tent to each main frame bar.

Note: Collapsing the center and front main frame poles part way down will make installation easier.

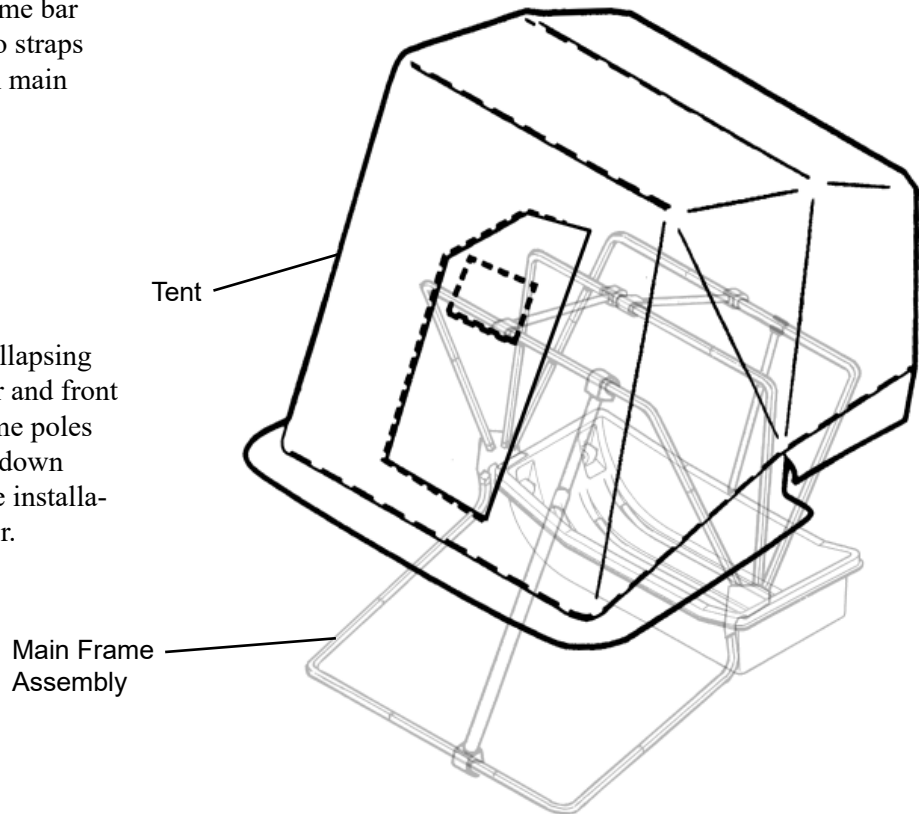

23. Once the canvas is on the frame and the Velcro attached, extend all of the frame bars upward and make sure all of the support poles are installed. Extend the front adjustable support pole so that the fabric in front is snug and not sagging. It will be necessary to loosen the back adjustable pole to achieve this. Once the front is set and the top support poles are in place, the back adjustable pole can be extended until it is snug. Install the plastic trim lock in the positions shown below.

Install the back center trim lock first and work your way around the sled, pulling the fabric snug as you go. The canvas will be trapped between the sled lip and the trim lock, and will also wrap underneath the sled lip providing a very good seal. Check the fit of the canvas and adjust as necessary before installing the screws (Item 29) to hold the trim lock (Item 30) in place. Use three screws on the long pieces and two screws on the shorter pieces.

Attach the eight plastic trim locks (Item 30) to the sled in the locations shown with the 45° angled edge to the inside of the sled.

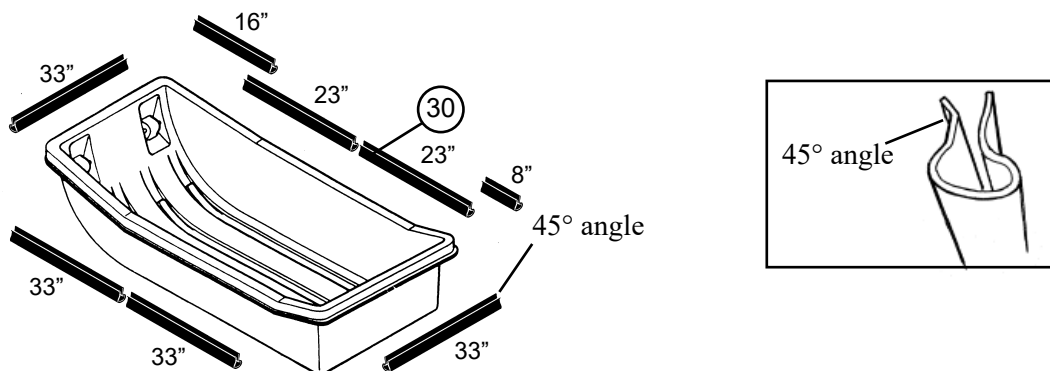

24. On the front of the fishhouse, start in the corners and work inward, snap the plastic trim seal on the canvas tent (Item 2) to the **lip** edge of the sled (Item 1). The tent (Item 2) will meet in the middle and should be free to open and close so it can be removed.

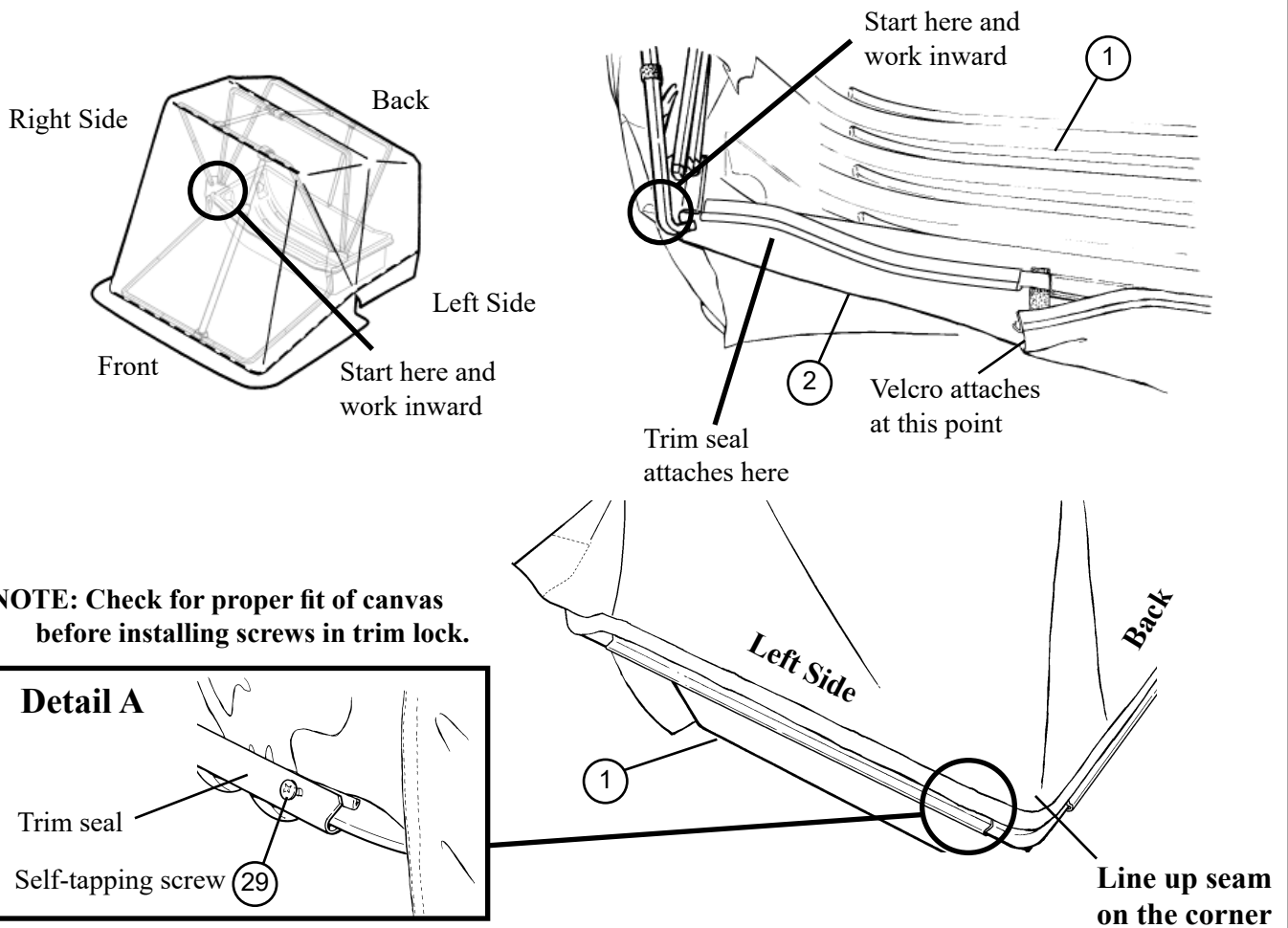

NOTE: Check for proper fit of canvas before installing screws in trim lock.

Detail A

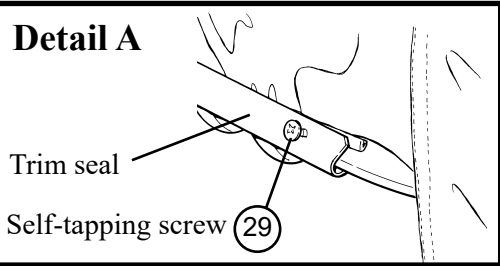

To Collapse Tent and Transport:

1. Remove support poles and store inside the sled.
2. Retract main frame bars by pressing in button while sliding the bar farther into the tube.
3. Fold the tent in towards the sled so all the bars are laying on top of the sled.
4. Tuck in excess tent material.
5. Ready for transport.
6. Reverse to set up the fishhouse again.

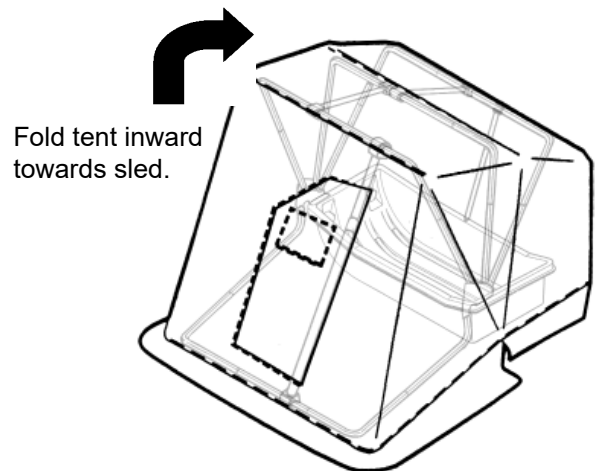

General Note: Be careful with tent windows in cold weather, as creasing or crushing them will cause breakage.



Caution: Use adequate ventilation. Portable heaters use up oxygen and emit carbon monoxide. Use reflectors and identifying lights after dark or during limited visibility.



Fish House Fabric Use and Care Guide

Care must be taken during use to avoid damaging the fabric. Follow these guidelines to help protect the fabric. The warranty will not cover damage to the fabric because of wear, improper packing or abuse.

1. Do not pack any gear on top of the fabric. Propane tanks and augers can be especially damaging because of the sharp edges and the extra weight associated with them.
2. When folding up the framework do not allow the fabric to be pinched between the hinge brackets and the frame poles.
3. Do not allow the fabric to be trapped between gear that is in the sled and the sled bottom. Gear that is sitting on top of the fabric will damage it due to vibration and impact.
4. Do not allow the fabric to come in contact with the heater or operate the heater too close to the fabric. The fabric can melt or the coating may be compromised from the heat.
5. When towing the fish house behind an ATV or snowmobile extra care must be taken because of the extreme amount of vibration and jarring that can occur. Padding or foam may need to be placed between the poles to protect the fabric. Any hard or sharp edge can damage the fabric if it is not padded or protected in some manner.
6. Do not pull on fabric that is frozen into the ice. This may damage the fabric or cause a seam to fail. Use a chisel to chop around the fabric to free it.
7. The fabric may be cleaned with warm water and a mild detergent if needed.
8. Always dry out the fabric after use and before storing.

By taking a few precautions to protect and maintain the fabric it will provide years of service.